

OAC-4000 Wiring Diagram

Outdoor Airflow Control for Thermostat-based Systems

Optional DCV Configuration: RS-485 BACnet MS/TP CO₂ Sensor or Occupancy Counter

IAT THERMAL DISPERSION
OUTDOOR AIRFLOW PROBE(S)

Probe #1 - 1 or 2 sensors
(required)

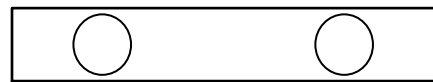

or

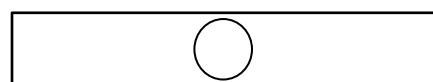

Probe #2 - 1 sensor
(optional if probe 1 is one sensor)

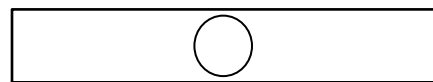

PROPORTIONAL
ACTUATOR
2-10 VDC
0-5/0-10 VDC
4-20 mA
(by others)

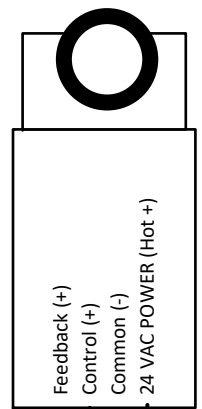

1 RS-485 may be "daisy-chained" to a remote B.A.S. BACnet objects are read-write. OAC controllers are a 1/2 load BACnet Master device. Set termination jumper (J3) on the OAC controller if it is located at the end of the RS-485 line. OAC controller RS-485 connections are non-isolated. Install a GreenTrol network isolator if an isolated RS-485 connection is required.

2 Actuator signal common is not required when a single transformer is provided to devices without isolated outputs.

3 N.O. contact closure relay. 30 VDC or 24 VAC @ 3A max. On-board jumper (J26) allows relay to drive an external LED (by others).

4 GP1 is configured as a binary 0/24 VAC input for thermostat applications. Occupied mode can be triggered by 0 VAC or 24 VAC via firmware parameter BI TRIG (default is 24 VAC).

FEP Plenum Rated
Cable w/DIN Plug
Included
10ft., 25ft. or 50 ft.

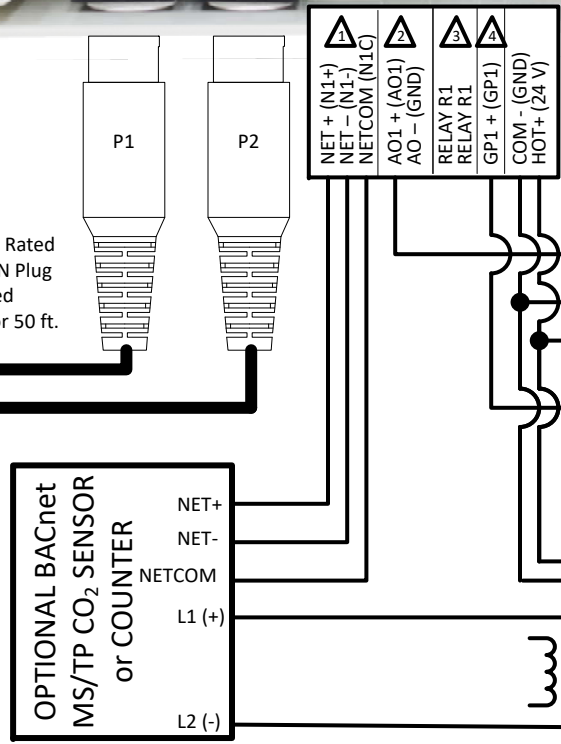

Occupied Control Enable Trigger:
(select one)

- 1** Fan On
 - 2** Stage 1 Compr. On*
 - 3** Occupied Mode
- * Heat pumps only

